

# DRAINAGE ITEMS

- Etched polypropylene face
- Face anchored in concrete
- Ultra-violet inhibitor
- Exceeds ASTM-D1693 Standards for Environmental Stress Cracking Resistance

**Cast Iron Grate  
ADA Compliant  
No. V09-71C 30  
lbs.**

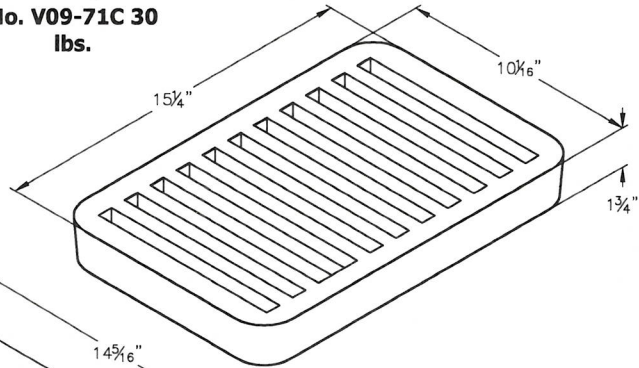

**Drain Box  
No. B09 BOX  
90 lbs.**

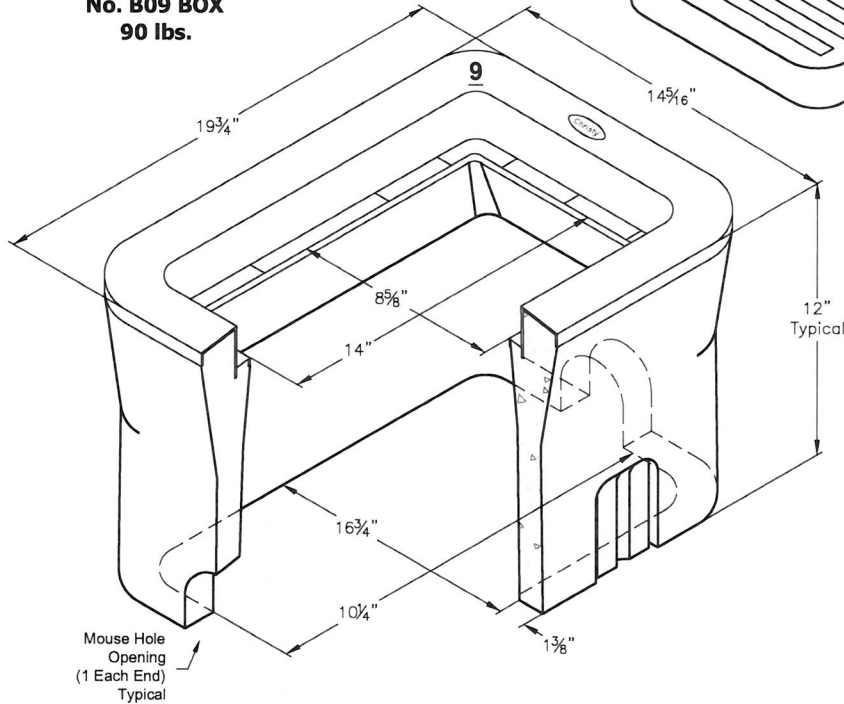

A curb type reinforced box for use in light drainage installations. Approximate dimensions and weight shown.

Oldcastle Ordering Code	Item	Approx. Shipping Weight	Description
B09BOX	BOX	90 lbs.	B09 Drain Box (10 1/4" x 16 3/4") - 28 per pallet
V09-71C	LID	30 lbs.	Cast Iron Grate - ADA Compliant
B09X12	EXTENSION	87 lbs.	12" Reinforced Concrete Box Extension - 28 per pallet
B09SL	SLAB	32 lbs.	Reinforced Concrete Slab (1 3/4" x 19 3/4")



## V09 BOX

FILE NAME: V09\_ISO

ISSUE DATE: January, 2011

## V09 DRAIN BOX 10-1/4" x 16-3/4"

**CHRISTY®**